

EXTRUDER



Weight	10000 kg
Total Power	52 KW
Extrusion Power	30 KW
Max. Product Height	600 mm
Production Speed	Up to 2.5 m/min
Concrete Capacity	2.5 m ³
Mould Change Time	30-60 min

Machine to manufacture precast prestressed concrete products, by means of the extrusion procedure, allowing the manufacture of products up to 600 mm height.

- Resimart® Extruder Machine is manufactured with a high wearing resistance material and is controlled by a variable frequency drive that allows total control over the extrusion process.
- By means of a posterior cast system, the product gets a perfect surface finish, allowing its final height regulation, when needed.
- The machine's translation is electronically controlled to suit the needs of the extrusion process.
- The total capacity of 2.5 m³ guarantees the shaping of big product quantities with the minimum interruptions in the process.
- This machine is provided with an automatic lubrication unit, which minimizes maintenance labors and avoids any kind of problems related to excessive wearing of the active parts.
- All mechanical, electrical and electronic units have been chosen with wide safety margins, using the leading brands in each category, to ensure the robustness and reliability of the machine and also to minimize maintenance labors.
- Can be provided with different casting units to allow the manufacture of different products, all of them driven from a single active frame and easily interchangeable to suit production needs.

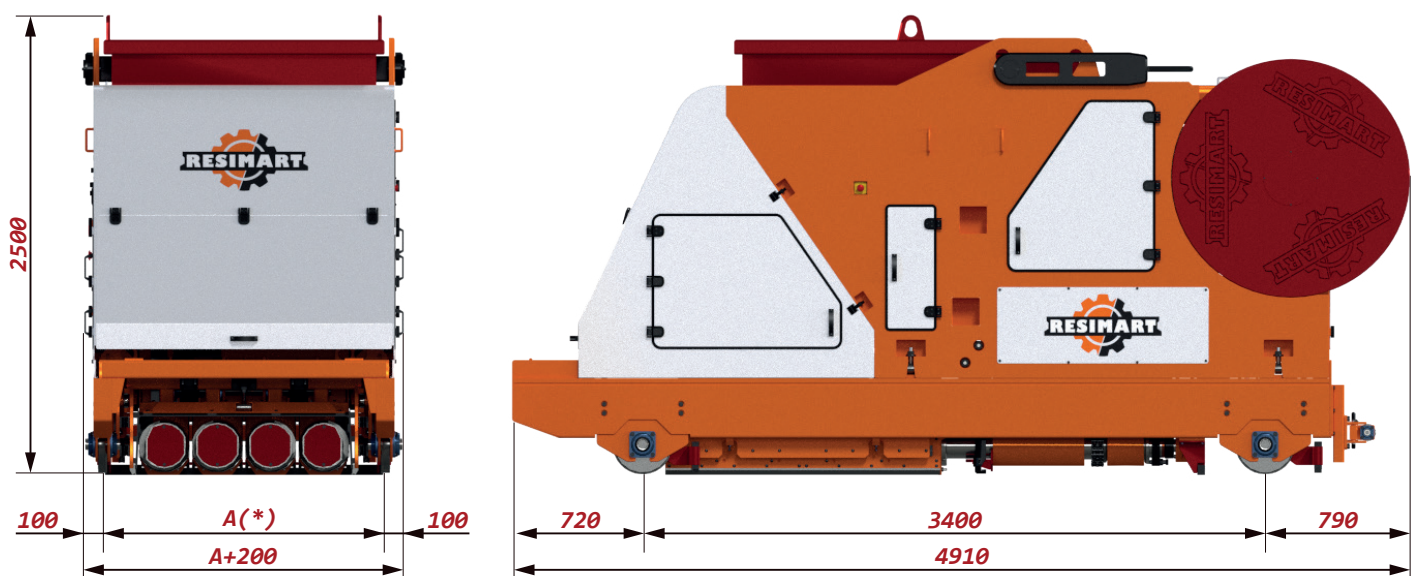

(*) According to model